

## Quality Irrigation Products



ISO 9001:2015  
Certified  
Quality Management



ANSI National Accreditation Board  
ACCREDITED  
ISO/IEC 17021  
MANAGEMENT SYSTEMS  
CERTIFICATION BODY

UMC is a ISO 9001:2015  
Certified Company



IRRIGATION  
POWERTRAIN

[www.umcproducts.com](http://www.umcproducts.com)

2920 Airway Ave, Costa Mesa, Ca. 92626  
phone: 714.437.9600 fax: 714.437.9700

## Final Drive Gearbox



### 765-U-AD™ Gearbox

**Designed for heavy spans, extreme conditions, corner systems, and lateral / linear carts**

The UMC® 765-U-AD™ gearbox is designed for use on center pivots and lateral / linear irrigation systems. It is typically used for the most extreme conditions and applications such as corner systems, lateral carts and heavy towers. It is the ideal choice for areas where extreme field conditions exist and/or machines run high annual hours of operation.

Part Number	Ratio
10162-105A	50:1

## Features and Benefits

The patented UMC® 765-U-AD™ gearbox is our largest and most durable high performance gearbox with a 50:1 gear ratio. It is a direct replacement for its predecessor, the 760-U™, and features several improvements that enhance load capacity, gear life and seal life.

- ▶ 2.50" diameter steel output shaft
- ▶ 50:1 gear ratio
- ▶ Cartridge input and output seals
- ▶ Patented Vented Internal Diaphragm with large expansion cavity for near zero psi pressure accumulation which increases seal life and reduces oil leaks
- ▶ 16-Bolt mounting pattern
- ▶

- ▶ Enhanced gear material that increases load capacity, reduces gear wear and lowers operating temperatures, extending gear life
- ▶ External seal protectors for input and output seals
- ▶ Largest output bearings in the industry
- ▶ Dual ended input shaft with hub cap for the unused end
- ▶ Large 3/4" oil fill and drain plugs for easier maintenance
- ▶ Filled with extreme pressure gear oil
- ▶ Extra long carriage bolts
- ▶ Allow use with reinforced rims
- ▶ Positive wheel register
- ▶ Bronze gear optional

[sales@umcproducts.com](mailto:sales@umcproducts.com)

# Universal Motion Components<sup>®</sup>

Dimensional Drawing

## 765-U-AD™ Final Drive Gearbox

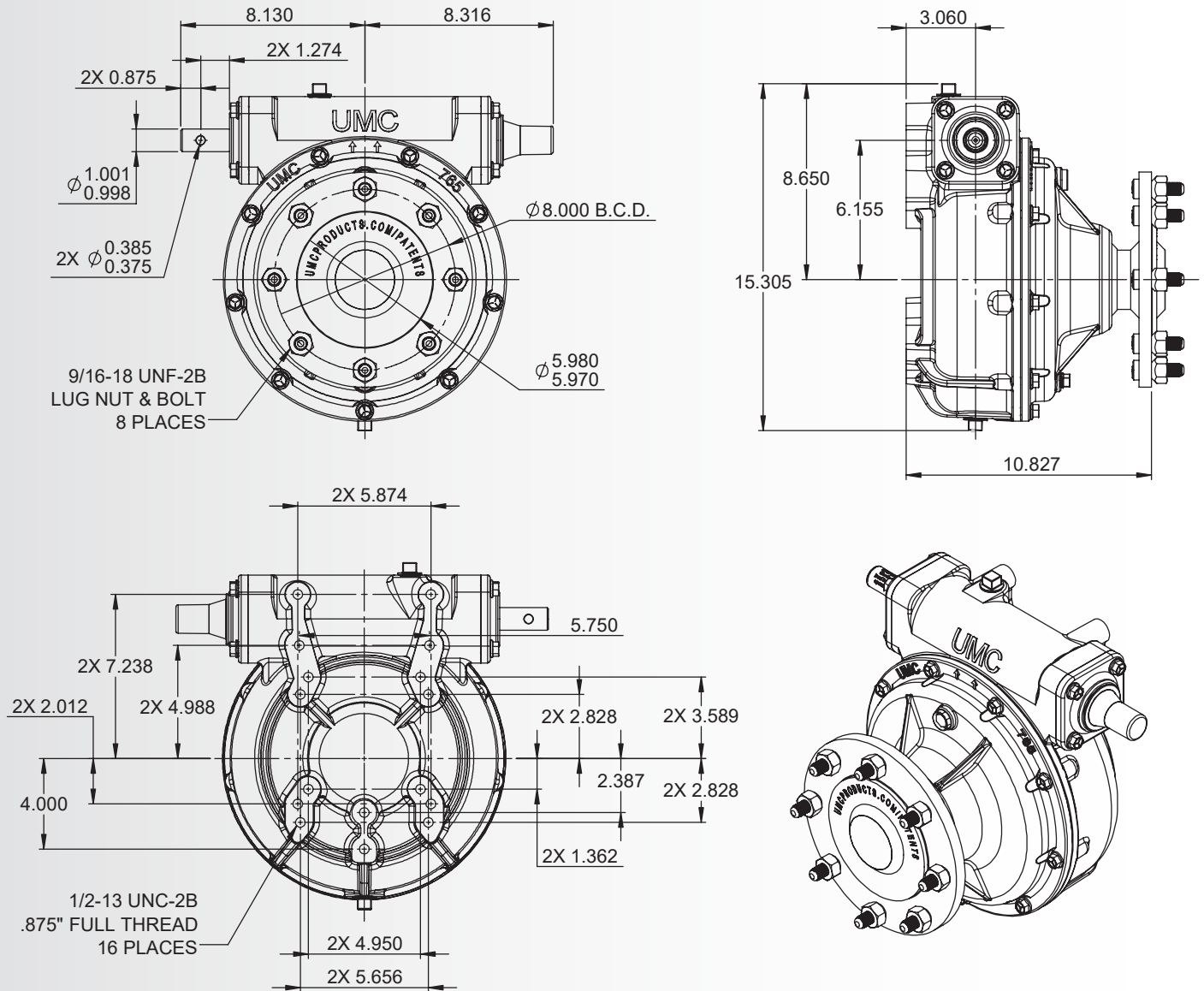

UNIVERSAL  
MOTION  
COMPONENTS



[www.umcproducts.com](http://www.umcproducts.com)



[sales@umcproducts.com](mailto:sales@umcproducts.com)

Universal Motion Components, Co. Inc.  
2920 Airway Ave, Costa Mesa, Ca. 92626  
Phone - 714-437-9600 Fax - 714-437-9700  
Web - <http://www.umcproducts.com>  
E-mail - [sales@umcproducts.com](mailto:sales@umcproducts.com)