

Universal Motion Components

# Quality Irrigation Products

ISO 9001:2000 CERTIFIED

2920 Airway Ave, Costa Mesa, Ca. 92626  
phone: 714.437.9600 fax: 714.437.9700



## Final Drive Gearbox



# 760-U

*HEAVY DUTY  
WHEEL BOX*

### Evaluation Specifications

- ▲ "NEW" External UV Resistant dust seals on Input and Output shafts
- ▲ Precision ground 2.5" output shaft.
- ▲ Peak Torque in excess of 100,000 In.-Lbs.
- ▲ Static load tested in excess of 145,000 In.-Lbs.
- ▲ 50:1 Ratio H.D. gear set.
- ▲ Double end input shaft.
- ▲ Full cycle expansion chamber.
- ▲ Taper roller bearings.
- ▲ Special crop guard seals.
- ▲ Each gearbox filled with extreme pressure gear oil.
- ▲ High strength cast iron bolt on end caps.
- ▲ High strength steel worm and output shafts.
- ▲ Easy access oil fill.
- ▲ Input shaft guard included.
- ▲ Dual output and input seals with external grease lube capabilities.
- ▲ Optional bronze gear.

Contact UMC at [sales@umcproducts.com](mailto:sales@umcproducts.com)

## Dimensional Drawing Final Drive Gearbox

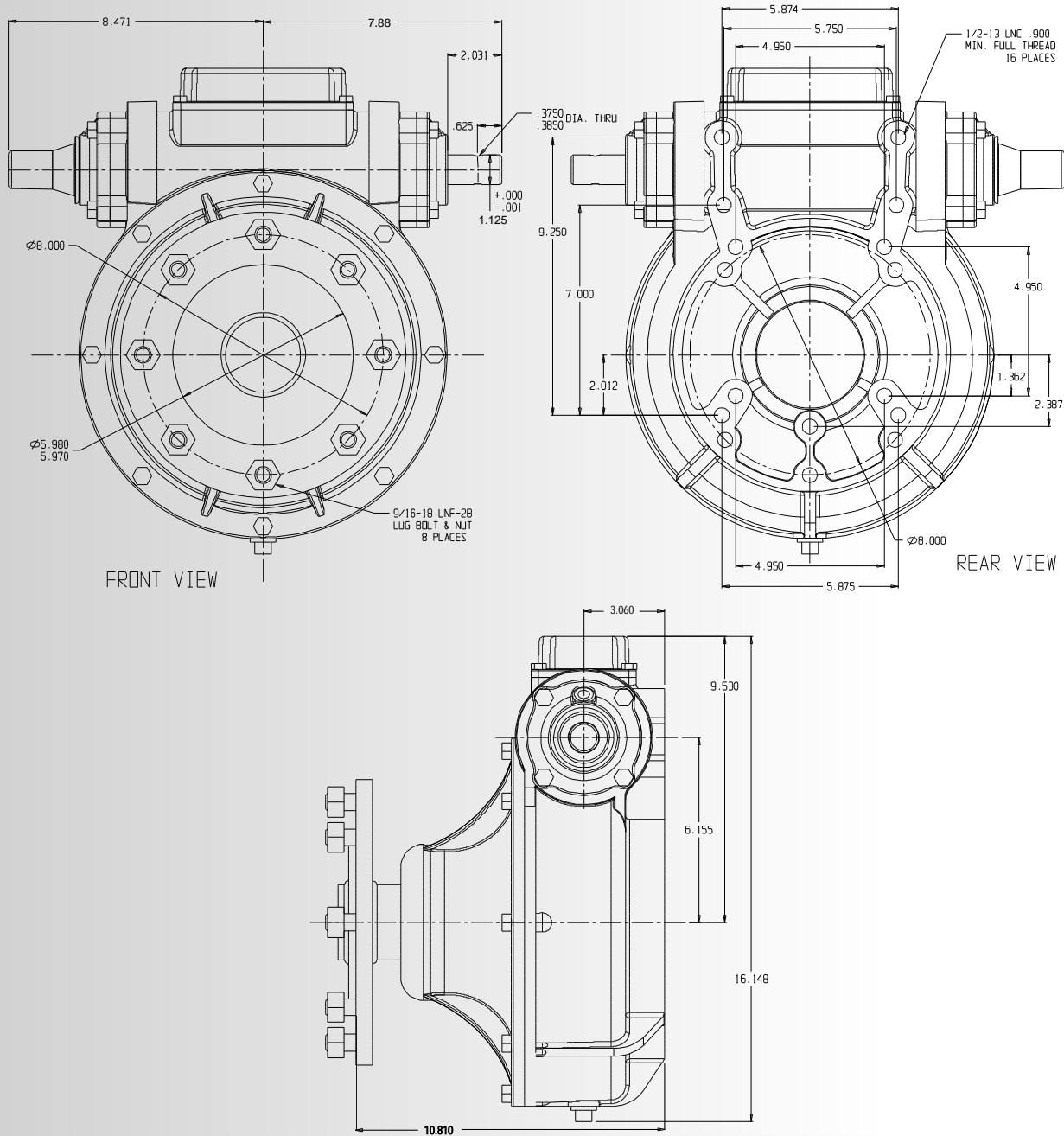

Fits most Lindsay, Valmont, Reinke, and Lockwood applications.

Contact UMC at [sales@umcproducts.com](mailto:sales@umcproducts.com)



Universal Motion Components, Co. Inc.  
2920 Airway Ave, Costa Mesa, Ca. 92626  
Phone: 714.437.9600 Fax: 714.437.9700  
Web: <http://www.umcproducts.com>  
E-mail: [sales@umcproducts.com](mailto:sales@umcproducts.com)