

QUALITY IRRIGATION
PRODUCTS

ISO 9001:2000 CERTIFIED

2920 Airway Ave, Costa Mesa, Ca. 92626
phone: 714.437.9600 fax: 714.437.9700



FINAL DRIVE GEARBOXES



Model Numbers:

→ 745 - U 50:1

Evaluation Specification:

- * 2 1/2" output shaft.
- * New Dual output seals standard.
- * Larger input bearings and reinforced housing.
- * Stainless steel expansion chamber.
- * Universal mount bolt pattern.
- * Full cycle expansion chamber; bellows-type expansion diaphragm.
- * Tapered roller bearings.
- * 50:1 worm gear ratio,
- * High strength cast iron bolt-on end caps.
- * Dual input seals.
- * Input / output shafts fitted with external UV resistant dust seals.
- * Includes rib neck carriage bolts with wheel nuts.
- * Each gearbox filled with extreme pressure, multi-purpose gear oil.
- * Top oil fill provision.
- * Each unit date stamped.
- * High strength steel worm and output shaft.
- * Input shaft guard included.

CONTACT UMC AT SALES@UMCPRODUCTS.COM

Dimensional Drawing
Final Drive Gearboxes

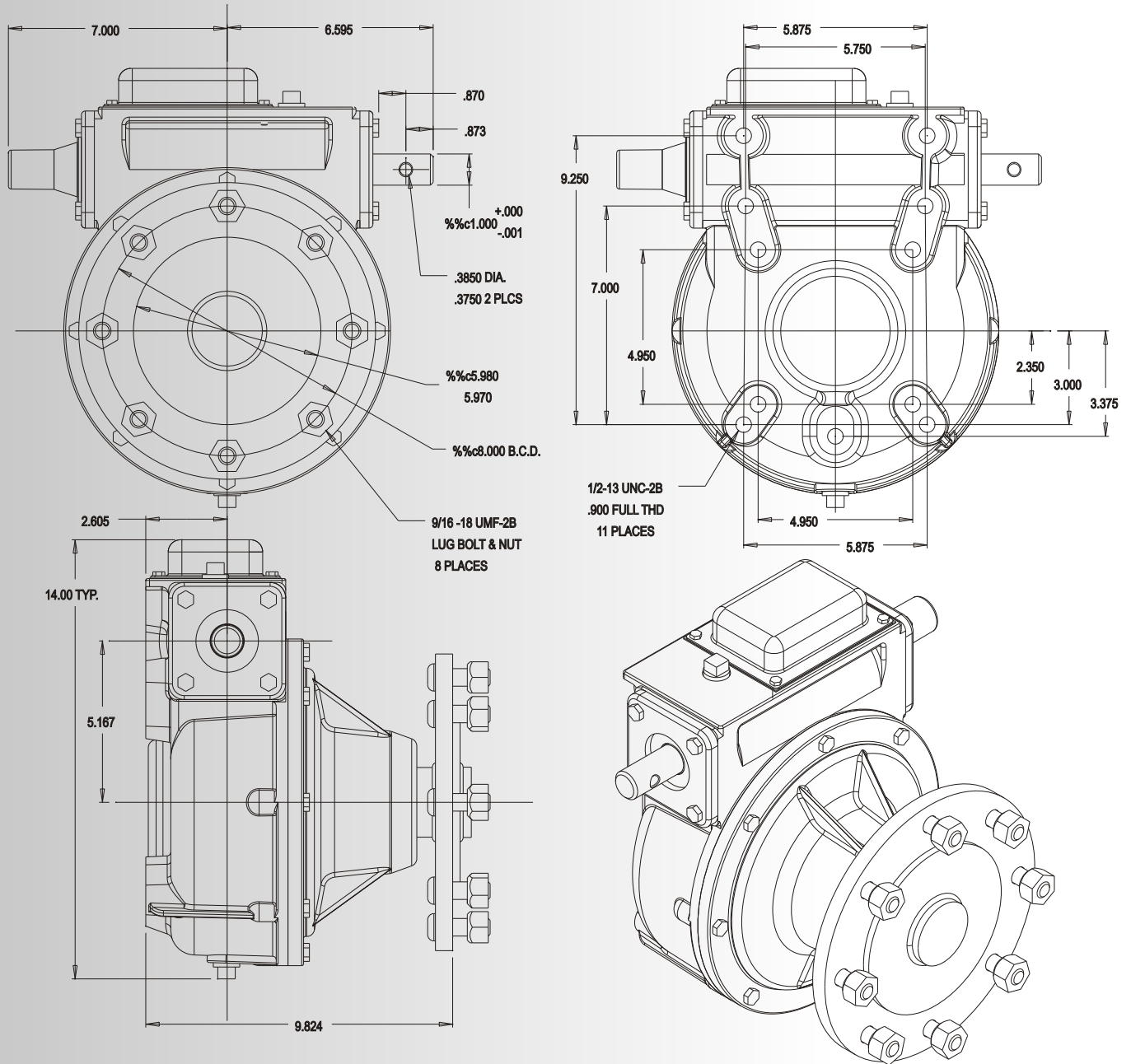

Universal mounting bolt pattern fits most Lindsay, Reinke, and Lockwood systems.

CONTACT UMC AT SALES@UMCPRODUCTS.COM



Universal Motion Components, Co. Inc.
2920 Airway Ave, Costa Mesa, Ca. 92626
Phone: 714.437.9600 Fax: 714.437.9700
Web: <http://www.umcproducts.com>
E-mail: sales@umcproducts.com